

REV	ECO	REV BY	DATE	APPD	DATE

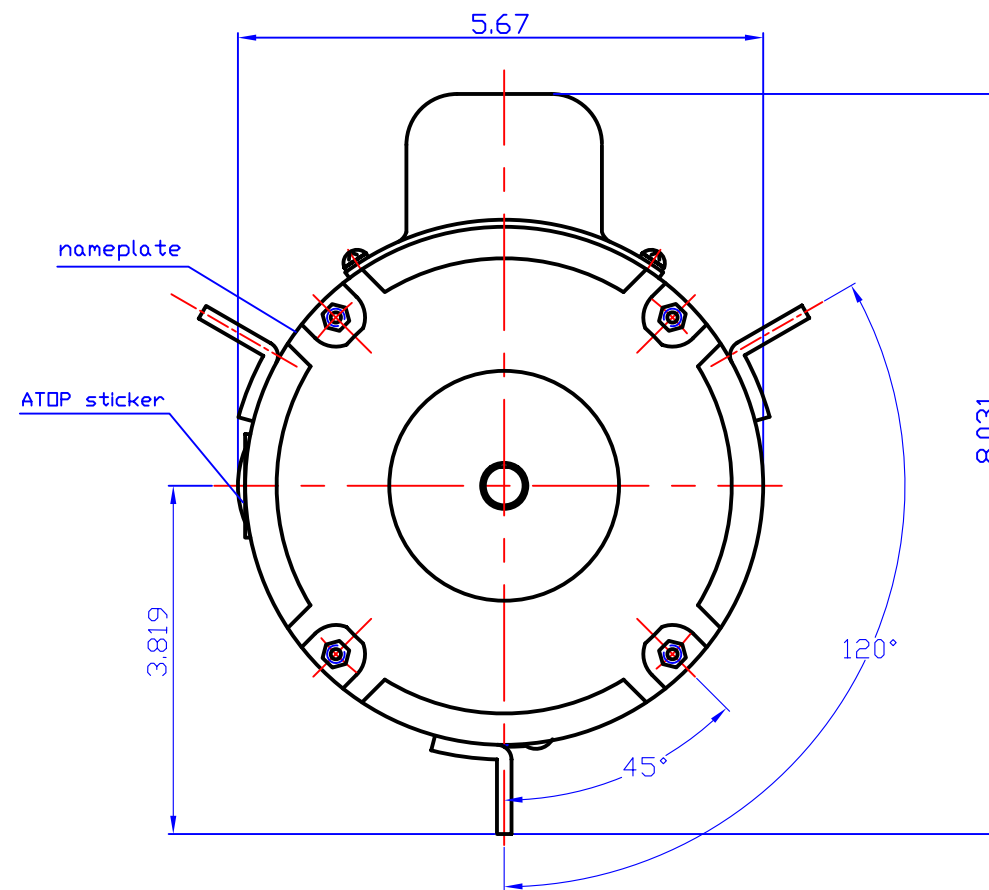

wiring diagram

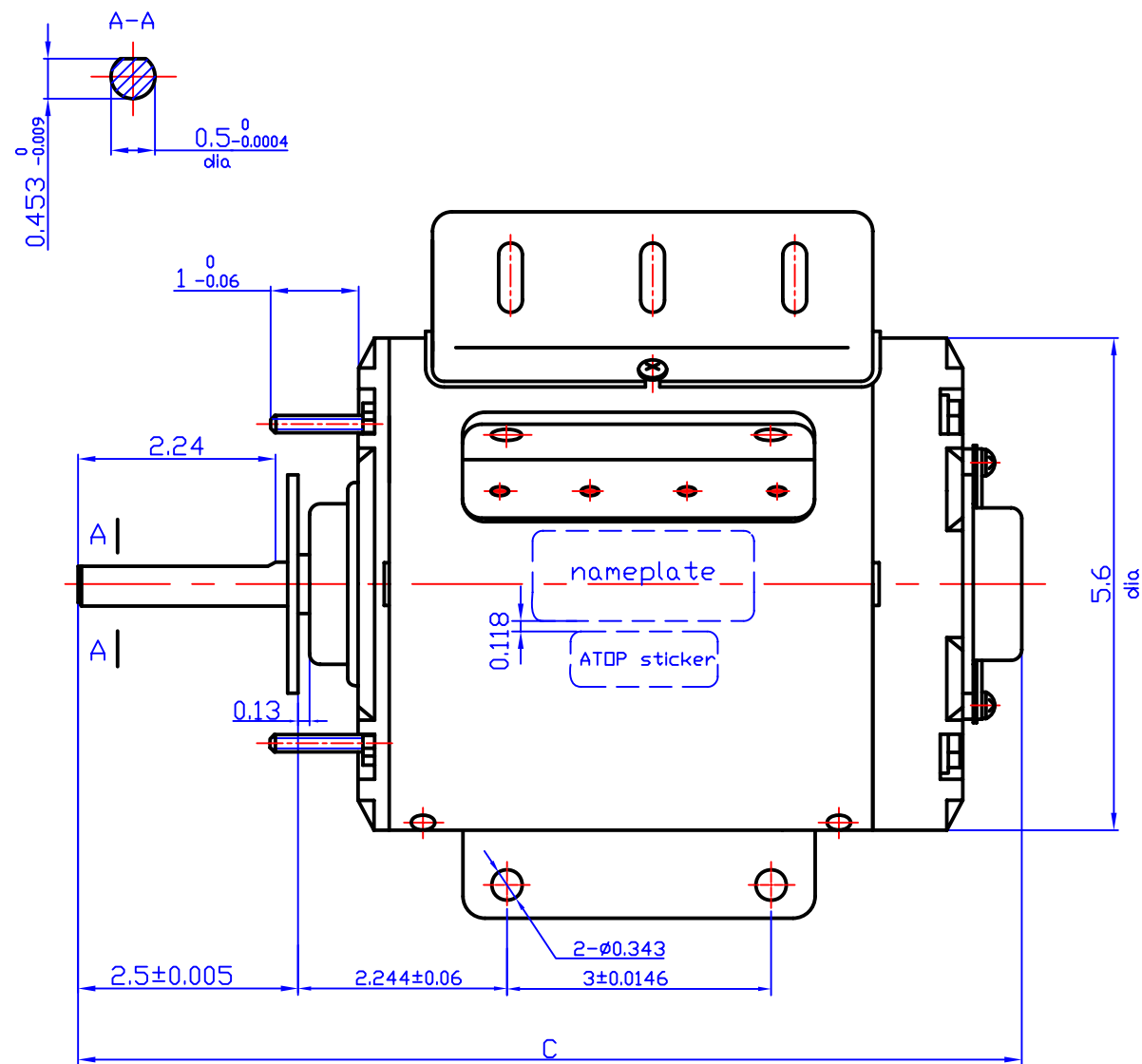
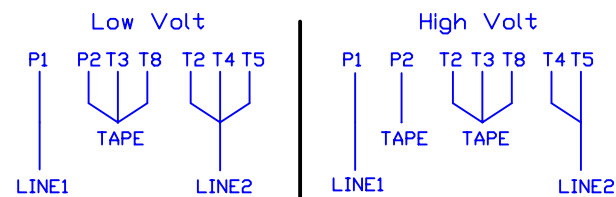

NOTE: To reverse rotation, interchange T5 & T8

AGI IND#	FRAME	Pole	PH	RPM	HP	Hz	Volt	thermal protector	C
F261T	48	6	1	1075	1/3	60	115/230	MEG65RX	11.34
F946T	48	6	1	1075	1/2	60	115/230	MEJ57RX	11.81

DR BY:
 APPD:
 FIRST ANGLE PROJECTION EDS DATE
 VERSION
 CONFIDENTIAL: THIS DRAWING AND ITS INFORMATION ARE THE EXCLUSIVE AND CONFIDENTIAL PROPERTY OF GW ELECTRIC (SHANGHAI) CORPORATION AND ARE NOT TO BE DISCLOSED, DUPLICATED, DISTRIBUTED OR OTHERWISE USED WITHOUT THE WRITTEN CONSENT OF GW ELECTRIC (SHANGHAI) CORPORATION.
 -ALL RIGHTS RESERVED.



AG-I MOTORTEC INC.,

DESCRIPTION

OUTLINE

SIZE A3 DWG NO

SCALE SHEET